



www.mytech-cnc.com

MYTECH[®]
ELEGANCE IN TECHNOLOGY

Vertical Machining Center

SHOU ZUAN Precision Machinery Co., Ltd.

No.46 Gen-Chen Rd., Shen Kung Dist.,
Taichung City 42952, Taiwan.

Tel. +886-4-2563 3015

Fax. +886-4-2563 2838

E-mail. sales@mytech-cnc.com

SHOU ZUAN Precision Machinery Co., Ltd. 886-4-25633015 2018.03





MT-440V/VS
MT-540V/VS

*High Speed Cutting For
Smaller Sizes.*

MT-750V/VS
MT-850V/VS

Vertical Machining Center

series

- Belt type spindle : 10,000 RPM
- Direct drive spindle : 10,000 / 12,000 RPM
- Arm type 20 tools ATC
- Rapid feedrate : 48M/min.

features

- The base structure is reinforced by internal ribbing to ensure high rigidity and stability.
- The machine processing fast, high precision, three axes rapid feedrate 48m/min, it is save time to achieve economic efficiency.
- Applicable Industries : 3C industries, Communications industry, Molds, Automotive and motorcycle parts.
- The ATC of supporting seat and column are one-piece. It is stability when tool change tool.

series

- Belt type spindle : 10,000 RPM
- Direct drive spindle : 10,000 / 12,000 RPM
- Arm type 24 tools ATC
- Feedrate is 36 M/min
- Roller type linear guideway and C3 ball screw on X, Y, Z - axis

features

- The ATC of supporting seat and column are one-piece. It is stability when tool change tool.
- High rigidity and Precision design, it is Suitable for heavy cutting and precision machining
- The base to easy drainage and Oil discharge system.



● Full guard with a guard on the top to preventing oil mist pollution.

MT-960V/VS
MT-1160V/VS

series

- Belt type spindle : 10,000 RPM
- Direct drive spindle : 10,000 / 12,000 RPM
- Arm type 24 tools ATC
- Roller type linear guideway and C3 ball screw on X, Y, Z - axis

features

- The spindle is directly coupled to the main motor. No belt or gear is used. The noise, backlash and vibration effects are dramatically reduced.
- Three axes adopts roller type linear guideway. It ensures the characteristics of high rigidity, low noise and low friction. High speed federate and contour cutting accuracy are achieved.
- Three axes transmission adopts C3 class high precision double nut preloaded ballscrews Dia.40mm.
- Reinforced column base greatly increase structural strength.
- Two super large side windows are standard for installation and cleanness.
- There don't have counter weight balance design, It will get good and high precision when machine be high speed machining.

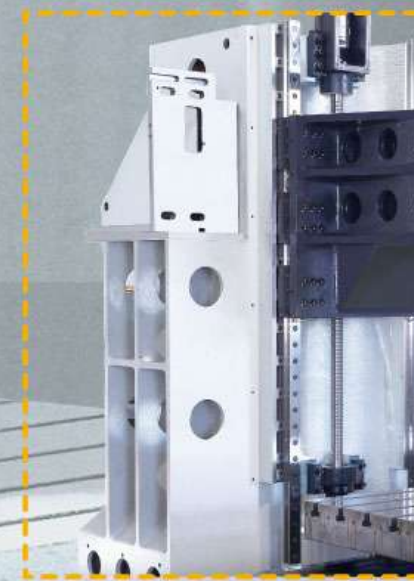

● The ATC of supporting seat and column are one-piece

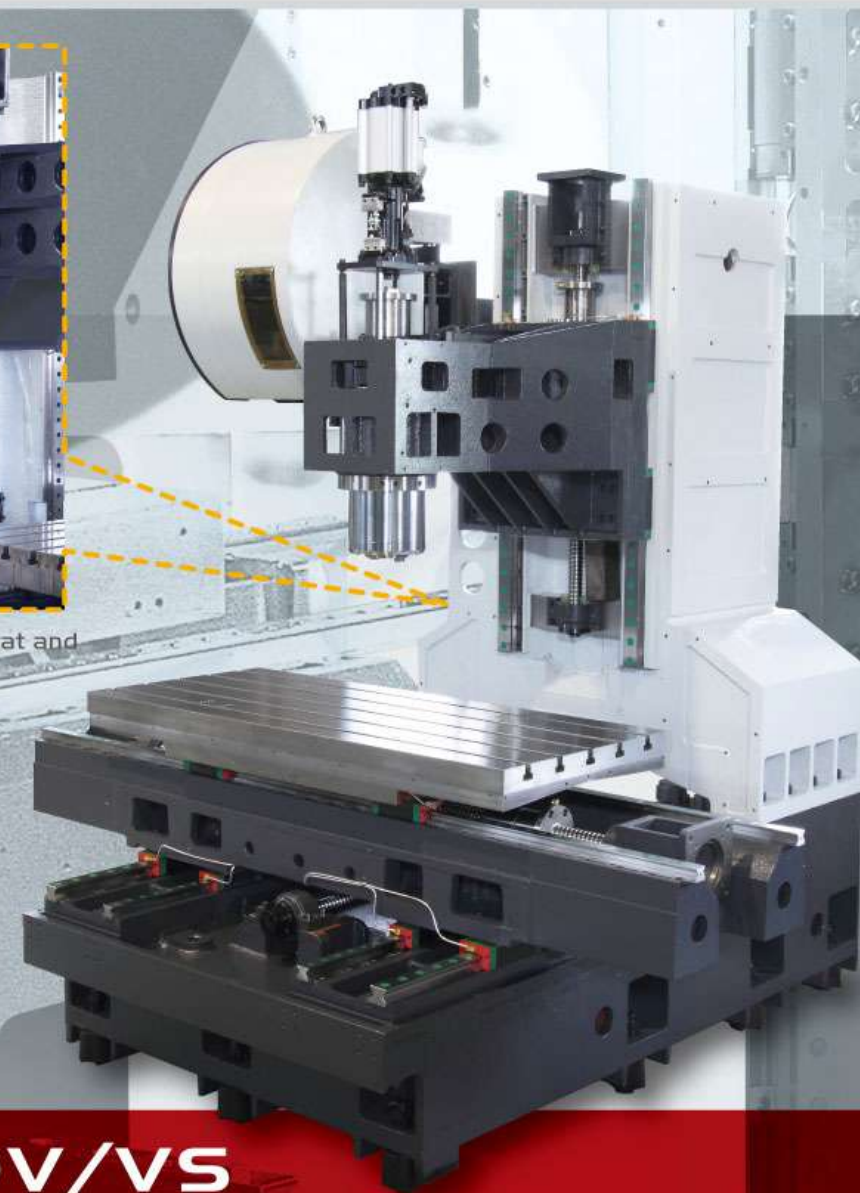

MT-1370V/VS

Vertical Machining Center

series

- Belt type spindle : 10,000 RPM
- Direct drive spindle : 10,000 / 12,000 RPM
- Table size : 1400 x 600mm
- Arm type 24 tools ATC
- C3 Ball Screw on X, Y, Z - axis

features

- Pneumatic counterweight system greatly lessens the ripple effect of inertia during the feed motion on Z axis.
- Six roller type slide blocks on X-axis, to ensure that the spindle accuracy and stable when machining cutting.
- Base frame consist of four heavy duty roller linear guides, greatly strengthened the fundamental structure of machine.
- Y axis used twin-chip auger (front-out). (Opt.)



Germany ZEISS 3D measuring System



Renishaw Laser

● In order to ensure product quality and meet customer needs, Mytech use Renishaw high precision instruments to detect precision laser and Ball Bar for ensuring position accuracy and excellent roundness.

Quality Control

MYTECH is the manufacturing factory who had Germany ZEISS 3D measuring equipment in Taiwan. All precision components are produced by us. The spirit of MYTECH is "Customers first, Best service, Excellent quality." We are able to offer the varieties of our products and services to meet the different inquiries by customers.

MYTECH provides the customers the good quality and high-precision milling machines which are also upgrade the product competitiveness for our user customers. We will insist on quality to earn long-term collaboration and development.



Ballbar diagnostics (%)

103319XY2

Operator : Yung

Date : 2014 - Nov - 22 11 : 58 : 51



Machine : Quick check

QC20 - W : 453F12, Last calibrated 2014 - 08 - 21

- 25% Reversal spikes Y
 - ▲ -1.0µm
 - ▼ -2.3µm
- 10% Lateral play Y
 - ▲ -0.1µm
 - ▼ -1.4µm
- 10% Squareness
 - 6.1µm/m
- 10% Scaling mismatch
 - 1.8µm
- 7% Cyclic error X
 - ↑ 0.7µm
 - ↓ 0.5µm

Circularity 3.4µm

- Run 1
- Run 2
- Fit 1
- Fit 2

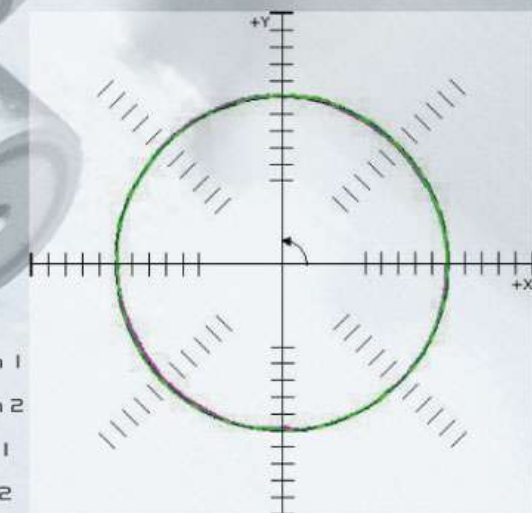

10.0µm/div



Ball Bar



Lubrication and Pressure System

- Both save money and environmental protection of the lubricating mechanism, pneumatic pump to provide three axes lubrication and build centralized equipment of pressure system.



Tool cabinet



Spindle oil cooler system

- For continuous and very high spindle speeds, the spindle cooling system efficiently takes away spindle heat, reduces spindle thermal deformation and ensures high speed accuracy.



Chip conveyer system for cutting aluminum

- Aluminum user's first choice, easy to clear cutting aluminum scrap collecting box.

Standard Accessories



Arm type 24 tools ATC

- Arm type ATC with 24 tools capacity. Fast and reliable roller gear cam ATC allows ATC time in 1.5 second, lowers the idle time and enhances the machining efficiency.



Automatic tool length measuring device

- The automatic tool length measuring system can measure and offset the tool length data onto the CNC controller automatically.



Oil skimmer system

- The disc type oil skimmer system is used for removing floating oil on coolant, preventing coolant deterioration and odor.



Full - closed splash guard

- Full guard with a guard on the top to preventing oil mist pollution.

Special Accessories



- Each machine are via standard test observing the cutting block completed Germany ZEISS 3D testing, strict quality control to ensure the accuracy guarantee.



CNC 4th Axis rotary table



CE

- Opening the front door and two side windows during machining will cause an emergency stop and ensures the operator's safety.



Mitsubishi controller (M70/M80/M720)



Fanuc controller (Oi-MF/3ii-MF)



Siemens controller (828D/840D)

- The control panel meets the safety requirements easy to learn and operate.
- The controller has breakage detection system. (Optional Equipment)

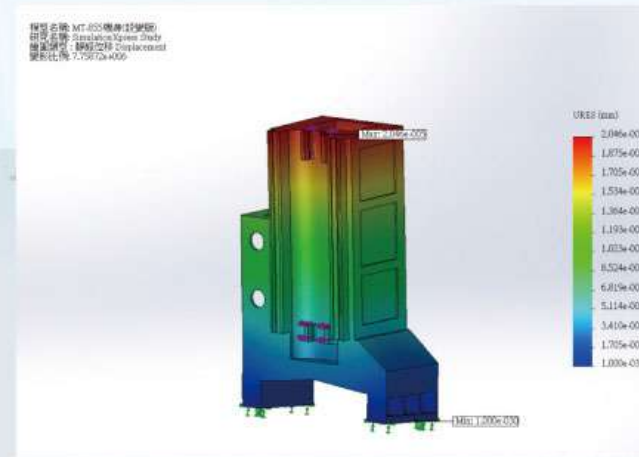

Column strain analysis

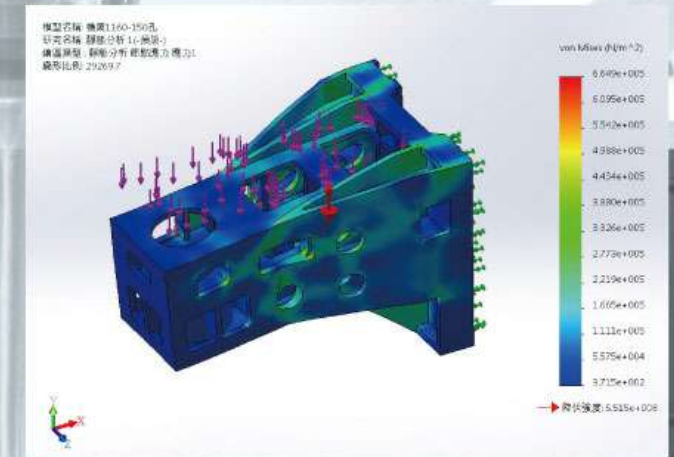

Spindle head strain analysis

Cutting Capability

Widely used in molds, auto parts, medical equipment and other processing.



Artificial joints



Tapping M2 x 0.4 pitch



Workpiece



Spiral

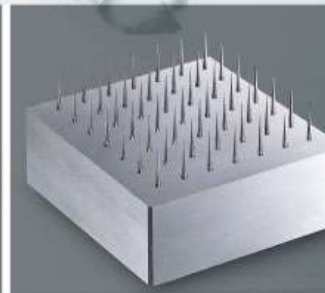

Deep needle

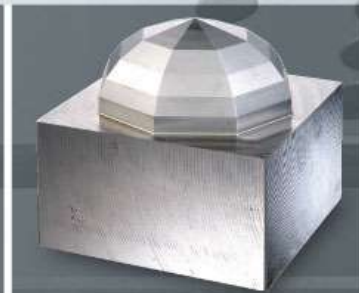

Lampshade

Ethernet Support Function



- Using transmission network, centralized management by PC processing program, you can instantly edit and quickly transfer the program to the machine, shorten lead time to prepare.

Tool shanks & Pull studs

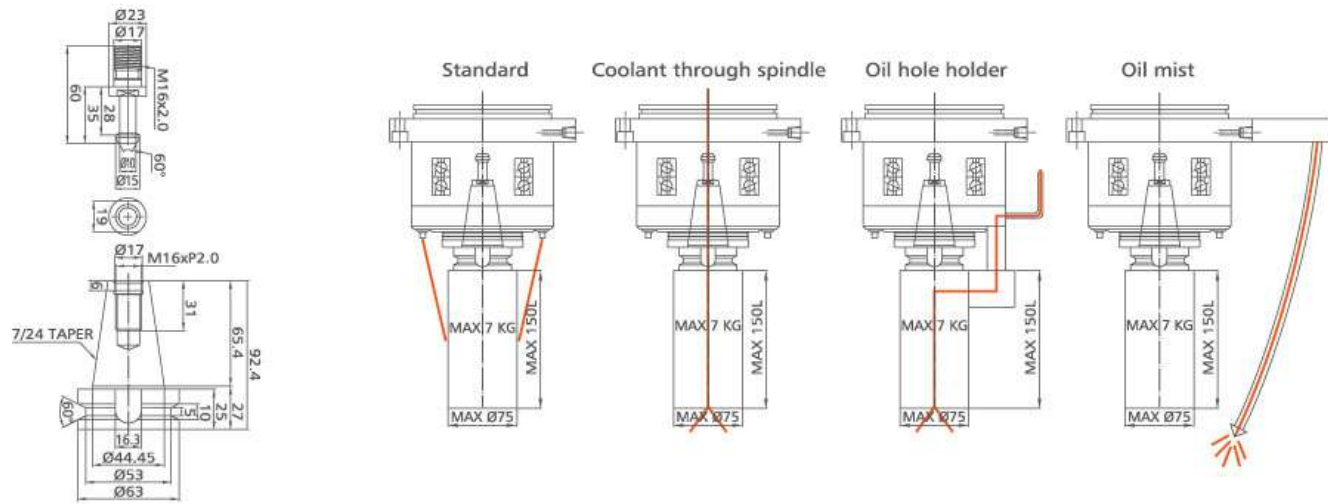

Dimensions

Unit : mm

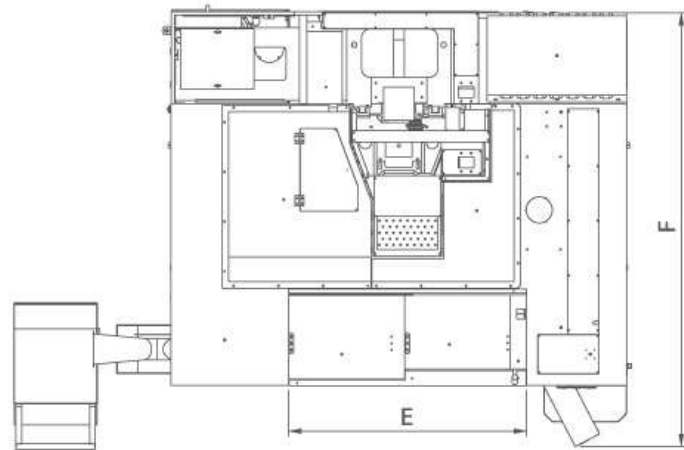

| MODEL | A | B | C | D | E | F |
|----------|------|------|------|-----------------|------|------|
| 440V/VS | 1700 | 2261 | 1860 | | | 2300 |
| 540V/VS | 1800 | 2761 | 1860 | MAX2220 MIN1770 | 775 | 2300 |
| 750V/VS | 2200 | 3285 | 2050 | MAX2710 MIN2210 | 740 | 2550 |
| 850V/VS | 2200 | 3285 | 2050 | MAX2729 MIN2229 | 740 | 2550 |
| 960V/VS | 2400 | 3350 | 2250 | MAX2810 MIN2210 | 1210 | 2876 |
| 1160V/VS | 2750 | 3700 | 2250 | MAX2810 MIN2210 | 1410 | 2876 |
| 1370V/VS | 3300 | 4250 | 2250 | MAX2920 MIN2220 | 1630 | 2876 |

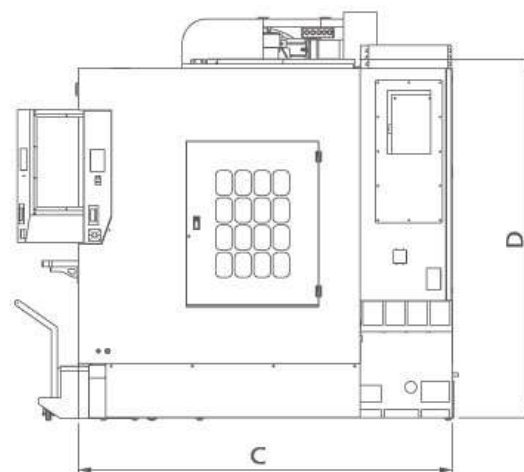
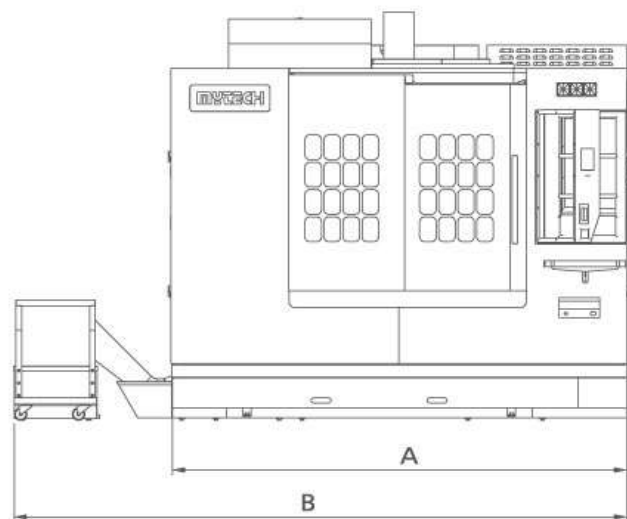

Specification

| MODEL | | MT-440V | MT-440VS | MT-540V | MT-540VS | MT-750V |
|--|-------------|---|---|---|---|---|
| TABLE | UNIT | | | | | |
| Size | mm | 550x450 | 550x450 | 650x450 | 650x450 | 800x450 |
| T-slot (width x no x distance) | mm x T | 18x5x90 | 18x5x90 | 18x5x90 | 18x5x90 | 18x5x90 |
| Maximum table load | kgs | 200 | 200 | 200 | 200 | 300 |
| TRAVEL | | | | | | |
| X, Y, Z -axis | mm | 450x400x400 | 450x400x400 | 550x430x450 | 550x430x450 | 700x500x500 |
| Table top surface to spindle nose | mm | 120-520 | 120-520 | 120-570 | 120-570 | 100-600 |
| Distance between spindle center and column surface | mm | 490 | 490 | 490 | 490 | 580 |
| X, Y, Z-Axis linear guideway | mm | 25/25/30 | 25/25/30 | 25/25/30 | 25/25/30 | 30/35/35 |
| X, Y, Z-Axis ball screw | | 28/28/32 | 28/28/32 | 28/28/32 | 28/28/32 | 32/32/32 |
| SPINDLE | | | | | | |
| Spindle holder | | BELT | DIRECT | BELT | DIRECT | BELT |
| Taper | | BT40 | BT40 | BT40 | BT40 | BT40 |
| Diameter | mm | φ 60 | φ 60 | φ 60 | φ 60 | φ 70 |
| Spindle speed | rpm | 10000 | 10000 | 10000 | 10000 | 10000 |
| FEED | | | | | | |
| Three axes | | Roller type linear guideway | Roller type linear guideway | Roller type linear guideway | Roller type linear guideway | Roller type linear guideway |
| Cutting feedrate X / Y / Z (G01) | m/min | 24/24/24 | 24/24/24 | 24/24/24 | 24/24/24 | 20/20/20 |
| Rapid feedrate X / Y / Z (G0) | m/min | 48/48/48 | 48/48/48 | 48/48/48 | 48/48/48 | 36/36/36 |
| ATC | | | | | | |
| Type | | ARM | ARM | ARM | ARM | ARM |
| Max. tool Dia | mm | φ 75 / φ 150 | φ 75 / φ 150 | φ 75 / φ 150 | φ 75 / φ 150 | φ 75 / φ 150 |
| Max. tool length | mm | 200 | 200 | 200 | 200 | 300 |
| Max. tool weight | kgs | 7 | 7 | 7 | 7 | 7 |
| Tool type | | BT40 | BT40 | BT40 | BT40 | BT40 |
| Tool magazine capacity | T | 20 | 20 | 20 | 20 | 24 |
| MOTORS | | | | | | |
| Spindle (Cont./30 min) | kw | 5.5/7.5 | 5.5/7.5 | 5.5/7.5 | 5.5/7.5 | 7.5/11 |
| X / Y / Z-Axis | kw | 1.5/1.5/3.0 (Mitsubishi) 1.4/1.4/3.0 (FANUC) | 1.5/1.5/3.0 (Mitsubishi) 1.4/1.4/3.0 (FANUC) | 1.5/1.5/3.0 (Mitsubishi) 1.4/1.4/3.0 (FANUC) | 1.5/1.5/3.0 (Mitsubishi) 1.4/1.4/3.0 (FANUC) | 2.0/2.0/3.0 (Mitsubishi) 1.6/1.6/4.0 (FANUC) |
| Coolant pump | kw | 0.75 | 0.75 | 0.75 | 0.75 | 0.75 |
| ATC motor | w | 350 | 350 | 350 | 350 | 350 |
| Air conditioner | w | 500 | 500 | 500 | 500 | 500 |
| Spindle oil cooler | w | 600 | 600 | 600 | 600 | 600 |
| Chip flush motor | w | 1290 | 1290 | 1290 | 1290 | 2580 |
| OTHER | | | | | | |
| Machine space (L x W) | mm | 1700x1860 | 1700x1860 | 1800x1860 | 1800x1860 | 2200x2050 |
| Splash guard | | Full-closed splash guard | Full-closed splash guard | Full-closed splash guard | Full-closed splash guard | Full-closed splash guard |
| Coolant tank capacity | L | 220 | 220 | 220 | 220 | 250 |
| Net weight | kgs | 3400 | 3400 | 3600 | 3600 | 4400 |
| Total power consumption | kw | 15 | 15 | 15 | 15 | 20 |

| MODEL | | MT-750VS | MT-850V | MT-850VS | MT-960V | MT-960VS | MT-1160V | MT-1160VS | MT-1370V | MT-1370VS | |
|--|--------|---|---|---|---|---|---|---|---|---|--|
| TABLE | | | | | | | | | | | |
| | UNIT | | | | | | | | | | |
| Size | mm | 800x450 | 900x500 | 900x500 | 1000x600 | 1000x600 | 1200x600 | 1200x600 | 1400x600 | 1400x600 | |
| T-slot (width x no x distance) | mm x T | 18x5x90 | 18x5x90 | 18x5x90 | 18x5x110 | 18x5x110 | 18x5x110 | 18x5x110 | 18x5x110 | 18x5x110 | |
| Maximun table load | kgs | 300 | 300 | 300 | 800 | 800 | 800 | 800 | 800 | 800 | |
| TRAVEL | | | | | | | | | | | |
| X, Y, Z -axis | mm | 700x500x500 | 810x500x500 | 810x500x500 | 900x570x570 | 900x600x600 | 1100x570x570 | 1100x600x600 | 1300x650x670 | 1300x650x690 | |
| Table top surface to spindle nose | mm | 100-600 | 100-600 | 100-600 | 120-690 | 110-710 | 120-690 | 110-710 | 120-790 | 105-805 | |
| Distance between spindle center and column surface | mm | 580 | 580 | 580 | 620 | 650 | 620 | 650 | 670 | 690 | |
| X, Y, Z-Axis linear guideway | mm | 30/35/35 | 35/35/35 | 35/35/35 | 35/45/45 | 35/45/45 | 35/45/45 | 35/45/45 | 35/45/45 | 34/35, 45/45 | |
| X, Y, Z-Axis ball screw | | 32/32/32 | 40/40/40 | 40/40/40 | 40/40/40 | 40/40/40 | 40/40/40 | 40/40/40 | 40/40/40 | 40/40/40 | |
| SPINDLE | | | | | | | | | | | |
| Spindle holder | | DIRECT | BELT | DIRECT | BELT | DIRECT | BELT | DIRECT | BELT | DIRECT | |
| Taper | | BT40 | BT40 | BT40 | BT40 | BT40 | BT40 | BT40 | BT40 | BT40 | |
| Diameter | mm | φ 70 | φ 70 | φ 70 | φ 60 | φ 70 | φ 60 | φ 70 | φ 60 | φ 70 | |
| Spindle speed | rpm | 10000 | 10000 | 10000 | 10000 | 10000 | 10000 | 10000 | 10000 | 10000 | |
| FEED | | | | | | | | | | | |
| Three axes | | Roller type linear guideway | Roller type linear guideway | Roller type linear guideway | Roller type linear guideway | Roller type linear guideway | Roller type linear guideway | Roller type linear guideway | Roller type linear guideway | Roller type linear guideway | |
| Cutting feedrate X / Y / Z (G01) | m/min | 20/20/20 | 20/20/20 | 20/20/20 | 20/20/20 | 20/20/20 | 20/20/20 | 20/20/20 | 20/20/20 | 20/20/20 | |
| Rapid feedrate X / Y / Z (G0) | m/min | 36/36/36 | 36/36/36 | 36/36/36 | 36/36/36 | 30/30/30 | 36/36/36 | 30/30/30 | 36/36/36 | 30/30/30 | |
| ATC | | | | | | | | | | | |
| Type | | ARM | ARM | ARM | ARM | ARM | ARM | ARM | ARM | ARM | |
| Max. tool Dia | mm | φ 75 / φ 150 | φ 75 / φ 150 | φ 75 / φ 150 | φ 75 / φ 150 | φ 75 / φ 150 | φ 75 / φ 150 | φ 75 / φ 150 | φ 75 / φ 150 | φ 75 / φ 150 | |
| Max. tool length | mm | 300 | 300 | 300 | 300 | 300 | 300 | 300 | 300 | 300 | |
| Max. tool weight | kgs | 7 | 7 | 7 | 7 | 7 | 7 | 7 | 7 | 7 | |
| Tool type | | BT40 | BT40 | BT40 | BT40 | BT40 | BT40 | BT40 | BT40 | BT40 | |
| Tool magazine capacity | T | 24 | 24 | 24 | 24 | 24 | 24 | 24 | 24 | 24 | |
| MOTORS | | | | | | | | | | | |
| Spindle (Cont./30 min) | kw | 7.5/11 | 7.5/11 | 7.5/11 | 7.5/11 | 11/15 | 11/15 | 11/15 | 11/15 | 11/15 | |
| X / Y / Z-Axis | kw | 2.0/2.0/3.0 (Mitsubishi) 1.6/1.6/4.0 (FANUC) | 2.0/2.0/3.0 (Mitsubishi) 1.6/1.6/4.0 (FANUC) | 2.0/2.0/3.0 (Mitsubishi) 1.6/1.6/4.0 (FANUC) | 3.0/3.0/3.5 (Mitsubishi) 3.0/3.0/4.0 (FANUC) | 3.0/3.0/3.5 (Mitsubishi) 3.0/3.0/4.0 (FANUC) | 3.0/3.0/3.5 (Mitsubishi) 3.0/3.0/4.0 (FANUC) | 3.0/3.0/3.5 (Mitsubishi) 3.0/3.0/4.0 (FANUC) | 3.0/3.0/4.5 (Mitsubishi) 3.0/3.0/4.0 (FANUC) | 3.0/3.0/4.5 (Mitsubishi) 3.0/3.0/4.0 (FANUC) | |
| Coolant pump | kw | 0.75 | 0.75 | 0.75 | 0.75 | 0.75 | 0.75 | 0.75 | 0.75 | 0.75 | |
| ATC motor | w | 350 | 350 | 350 | 350 | 350 | 350 | 350 | 350 | 350 | |
| Air conditioner | w | 500 | 500 | 500 | 500 | 500 | 500 | 500 | 500 | 500 | |
| Spindle oil cooler | w | 600 | 600 | 600 | 600 | 600 | 600 | 600 | 600 | 600 | |
| Chip flush motor | w | 2580 | 2580 | 2580 | 2580 | 2580 | 2580 | 2580 | 2580 | 2580 | |
| OTHER | | | | | | | | | | | |
| Machine space (L x W) | mm | 2200x2050 | 2200x2050 | 2200x2050 | 2400x2250 | 2400x2250 | 2750x2250 | 2750x2250 | 3300x2250 | 3300x2250 | |
| Splash guard | | Full-closed splash guard | Full-closed splash guard | Full-closed splash guard | Full-closed splash guard | Full-closed splash guard | Full-closed splash guard | Full-closed splash guard | Full-closed splash guard | Full-closed splash guard | |
| Coolant tank capacity | L | 250 | 250 | 250 | 280 | 280 | 280 | 280 | 350 | 350 | |
| Net weight | kgs | 4400 | 4500 | 4500 | 7000 | 7000 | 7300 | 7300 | 8000 | 8000 | |
| Total power consumption | kw | 20 | 20 | 20 | 25 | 25 | 25 | 25 | 30 | 30 | |

Standard Accessories

- Full- closed splash guard
- X,Y,Z-Axis telescopic guideway cover
- Oil skimmer system
- Water gun and air gun
- Chips flush system
- Tools box
- LED work lamp
- Arm type 20/24 tools ATC
- Automatic lubrication system
- Heat exchanger for electric cabinet
- 3 color Alarm light
- MITSUBISHI controller M70
- Screw type chip conveyer
- Automatic tool length measuring device
- Spindle oil cooler system
- Spindle splash ring

Option Accessories

- FANUC system controller
- SIEMENS system controller
- Direct type spindle 12,000/15,000 RPM
- Built type spindle 20,000/24,000 RPM
- Coolant through spindle
- Air conditioner
- Transformer
- Voltage regulator
- Flat type chip conveyer
- CE norm
- 3-Axes optical scale
- Breakage detection system
- Oil mist collector
- Inverter ATC system
- X and Y Axis coolant through ball screws
- CNC 4th Axis rotary table
- CNC 4th & 5th Axis rotary table